



**CONFIDENTIAL**

THIS DOCUMENT AND INFORMATION CONTAINED HEREIN IS PROPRIETARY AND CONFIDENTIAL TO PRECOR STRENGTH INCORPORATED. RECIPIENTS OF THIS DOCUMENT AGREE THAT THIS DOCUMENT AND INFORMATION WILL NOT BE USED FOR ANY PURPOSE, REPRODUCED OR COPIED, OR DISCLOSED TO ANY THIRD PARTY, EITHER IN WHOLE OR IN PART WITHOUT PRIOR EXPRESS WRITTEN PERMISSION OF PRECOR STRENGTH, INCORPORATED.

**PRECOR** USA  
PRECOR STRENGTH, INC.

28936 AVE WILLIAMS  
VALENCIA, CA 91355  
TELEPHONE: 661-362-0300

SIGN IN BLUE OR BLACK INK ONLY		
DRWN BY	01.02.07	MGP
DWG CHK		
ENG	01.02.07	RSG
MPG ENG		
CS		
QA		
ID		
REG		

UNLESS OTHERWISE SPECIFIED:  
DIMENSIONS ARE IN INCHES  
TOLERANCES ARE:  
LIN .X=±0.1 .XXX=±0.010  
LIN .XX=±0.02 .XXXX=±0.0001  
ANGULAR: ±1.0°  
ALL DIMS AFTER PLATING  
BREAK ALL SHARP EDGES  
REMOVE ALL BURRS  
ALL ANGLES & BENDS 90°  
DWG PER ASME Y14.5M-1994  
DO NOT SCALE DRAWING  
ALL MACHINED SURFACES

PRODUCT:		STRENGTH
ASSEMBLY CONNECTION, 10.5, W/ 1 PULLEY HSG		
DWG. NO.	CW31868-402	SUBREV A

SIZE	PAGE	OF
C	1	1

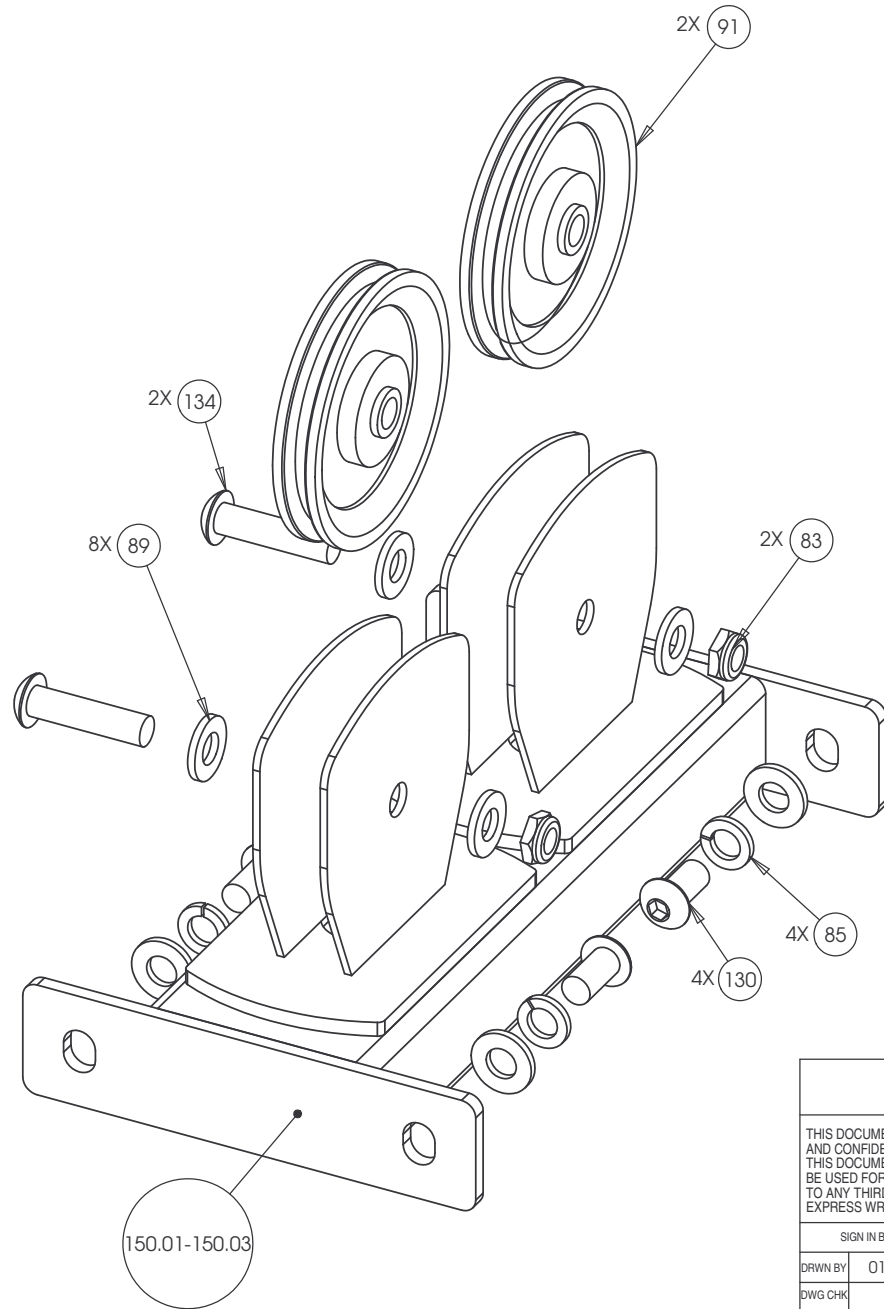

## CONFIDENTIAL

THIS DOCUMENT AND INFORMATION CONTAINED HEREIN IS PROPRIETARY AND CONFIDENTIAL TO PRECOR STRENGTH INCORPORATED. RECIPIENTS OF THIS DOCUMENT AGREE THAT THIS DOCUMENT AND INFORMATION WILL NOT BE USED FOR ANY PURPOSE, REPRODUCED OR COPIED, OR DISCLOSED TO ANY THIRD PARTY, EITHER IN WHOLE OR IN PART WITHOUT PRIOR EXPRESS WRITTEN PERMISSION OF PRECOR STRENGTH, INCORPORATED.

**PRECOR** USA  
PRECOR STRENGTH, INC.

28936 AVE WILLIAMS  
VALENCIA, CA 91355  
TELEPHONE: 661-362-0300

SIGN IN BLUE OR BLACK INK ONLY		UNLESS OTHERWISE SPECIFIED: DIMENSIONS ARE IN INCHES	
DRWN BY	01.02.07	MGP	TOLERANCES ARE:
DWG CHK			LIN .X=±0.1 .XXX=±0.010
ENG	01.02.07	RSG	LIN .XX=±0.02 .XXXX=±0.0001
MFG ENG			ANGULAR: ±1.0°
CS			ALL DIMS AFTER PLATING
QA			BREAK ALL SHARP EDGES
ID			REMOVE ALL BURRS
REG			ALL ANGLES & BENDS 90°
			DWG PER ASME Y14.5M-1994
			DO NOT SCALE DRAWING
			ALL MACHINED SURFACES

PRODUCT:  
STRENGTH

ASSEMBLY  
CONNECTION, 13.75, W/  
2 PULLEY HSG

DWG. NO. CW31876-402  
SUBREV A

SIZE PAGE OF  
C 1 1

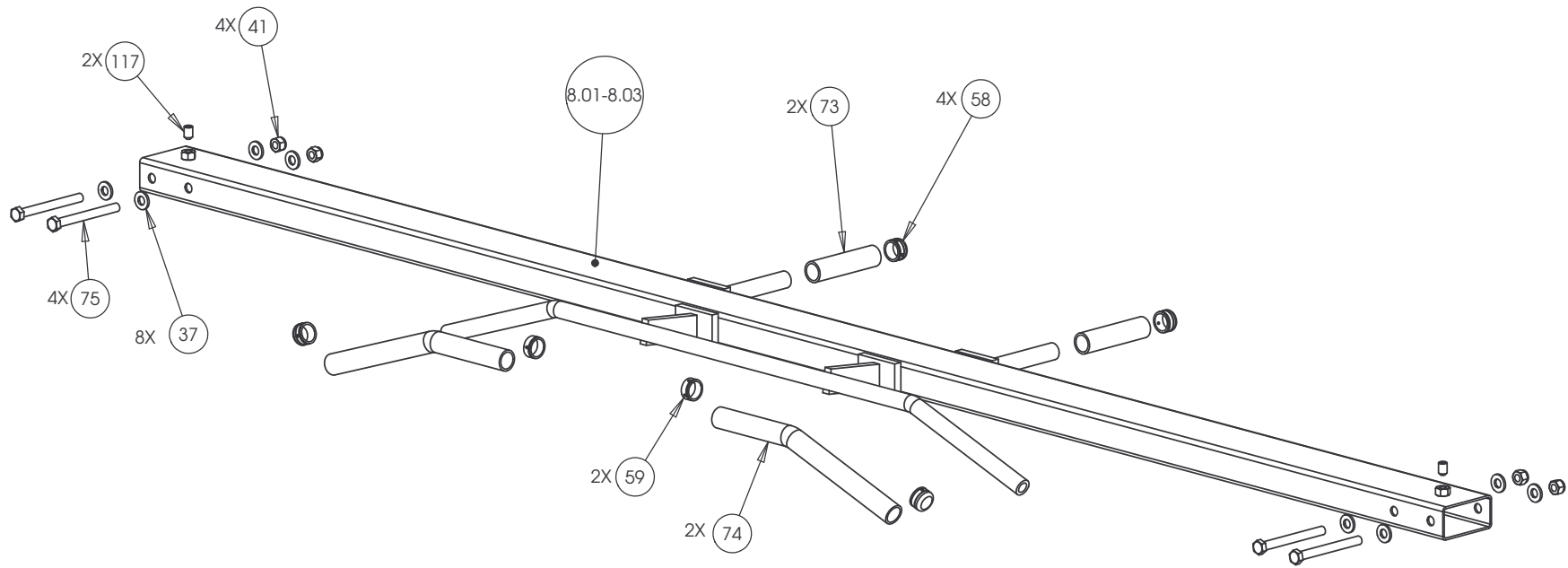

**CONFIDENTIAL**

THIS DOCUMENT AND INFORMATION CONTAINED HEREIN IS PROPRIETARY AND CONFIDENTIAL TO PRECOR STRENGTH INCORPORATED. RECIPIENTS OF THIS DOCUMENT AGREE THAT THIS DOCUMENT AND INFORMATION WILL NOT BE USED FOR ANY PURPOSE, REPRODUCED OR COPIED, OR DISCLOSED TO ANY THIRD PARTY, EITHER IN WHOLE OR IN PART WITHOUT PRIOR EXPRESS WRITTEN PERMISSION OF PRECOR STRENGTH, INCORPORATED.

**PRECOR USA**  
PRECOR STRENGTH, INC.

28936 AVE WILLIAMS  
VALENCIA, CA 91355  
TELEPHONE: 661-362-0300

SIGN IN BLUE OR BLACK INK ONLY			UNLESS OTHERWISE SPECIFIED: DIMENSIONS ARE IN INCHES			PRODUCT:	
DRWN BY	01.02.07	MGP	TOLERANCES ARE:			STRENGTH	
DWG CHK			LIN	.X=±0.1	.XXX=±0.010	ASSEMBLY CONNECTION, 107 IN, CROSSBEAM W-HANDLES	
ENG	01.02.07	RSG	LIN	.XX=±0.02	.XXXX=±0.0001		
MFG ENG			ANGULAR: ±1.0°				
CS			ALL DIMS AFTER PLATING				
QA			BREAK ALL SHARP EDGES				
ID			REMOVE ALL BURRS				
REG			ALL ANGLES & BENDS 90°			DWG. NO.	
			DWG PER ASME Y14.5M-1994			CW31878-401	
			DO NOT SCALE DRAWING			SUBREV	
			ALL MACHINED SURFACES			A	
			SIZE	PAGE	OF		
			C	1	1		

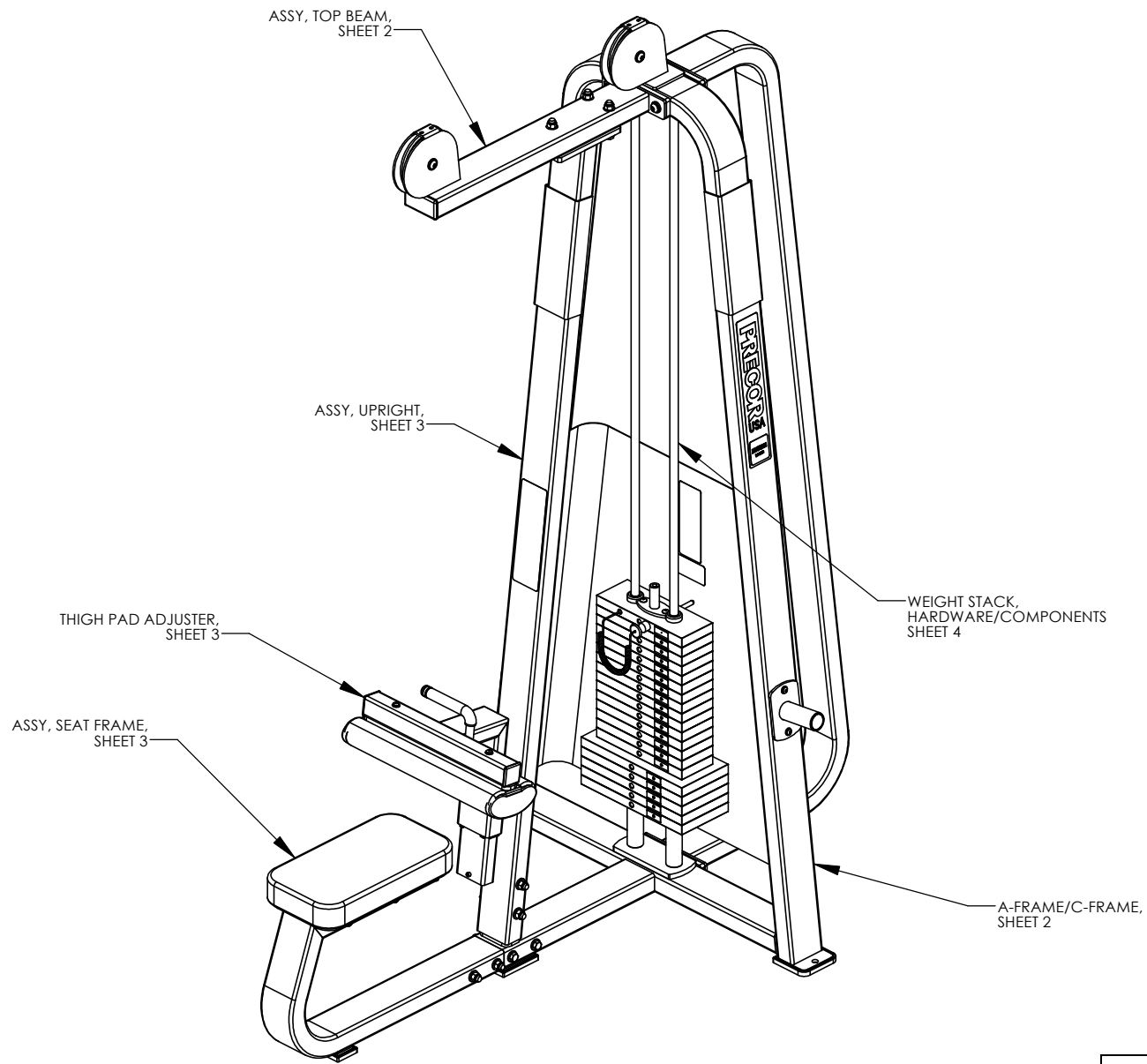

P/N: CW31932-402	SUBREV: C
DRAWN BY: JEC	DATE: 09.11.08
SHEET 1 OF 4	

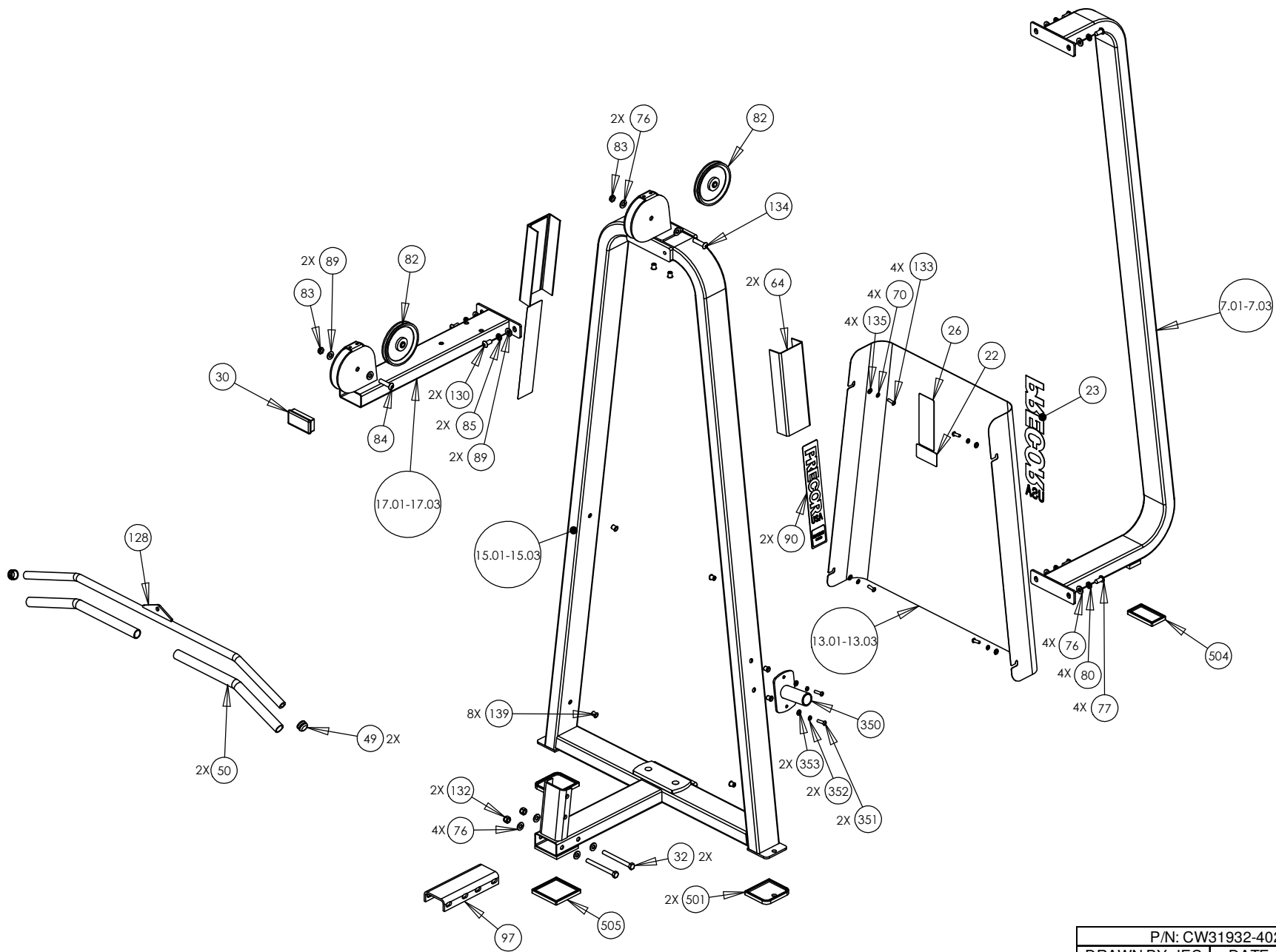

P/N: CW31932-402	SUBREV: C
DRAWN BY: JEC	DATE: 09.11.08
SHEET 2 OF 4	

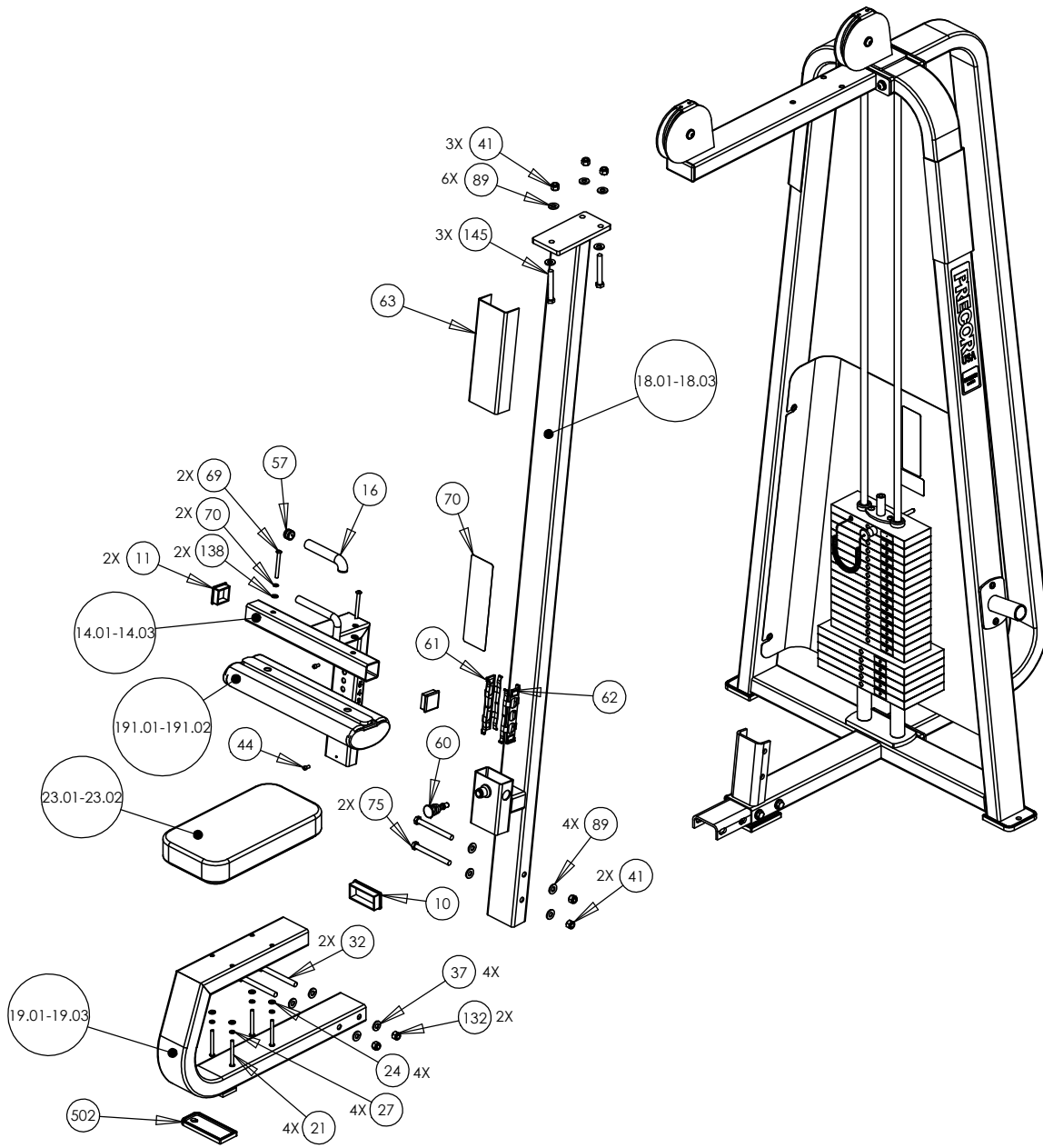

P/N: CW31932-402	SUBREV: C
DRAWN BY: JEC	DATE: 09.11.08
SHEET 3 OF 4	

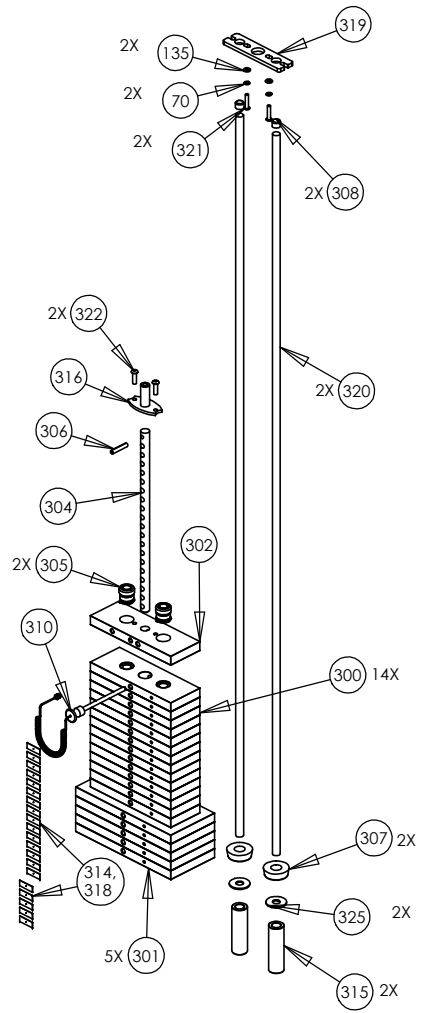
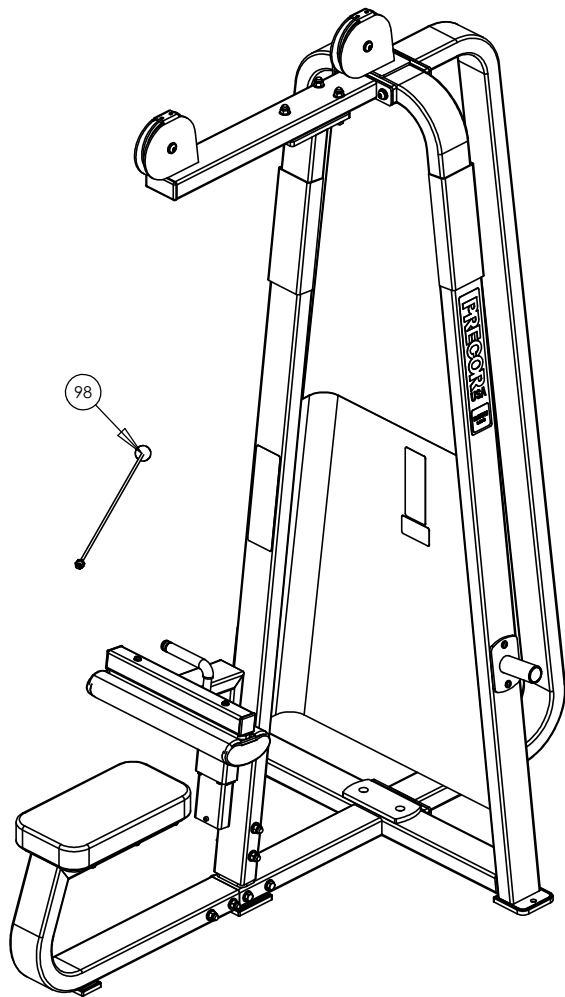

P/N: CW31932-402		SUBREV: C
DRAWN BY: JEC	DATE: 09.11.08	SHEET 4 OF 4

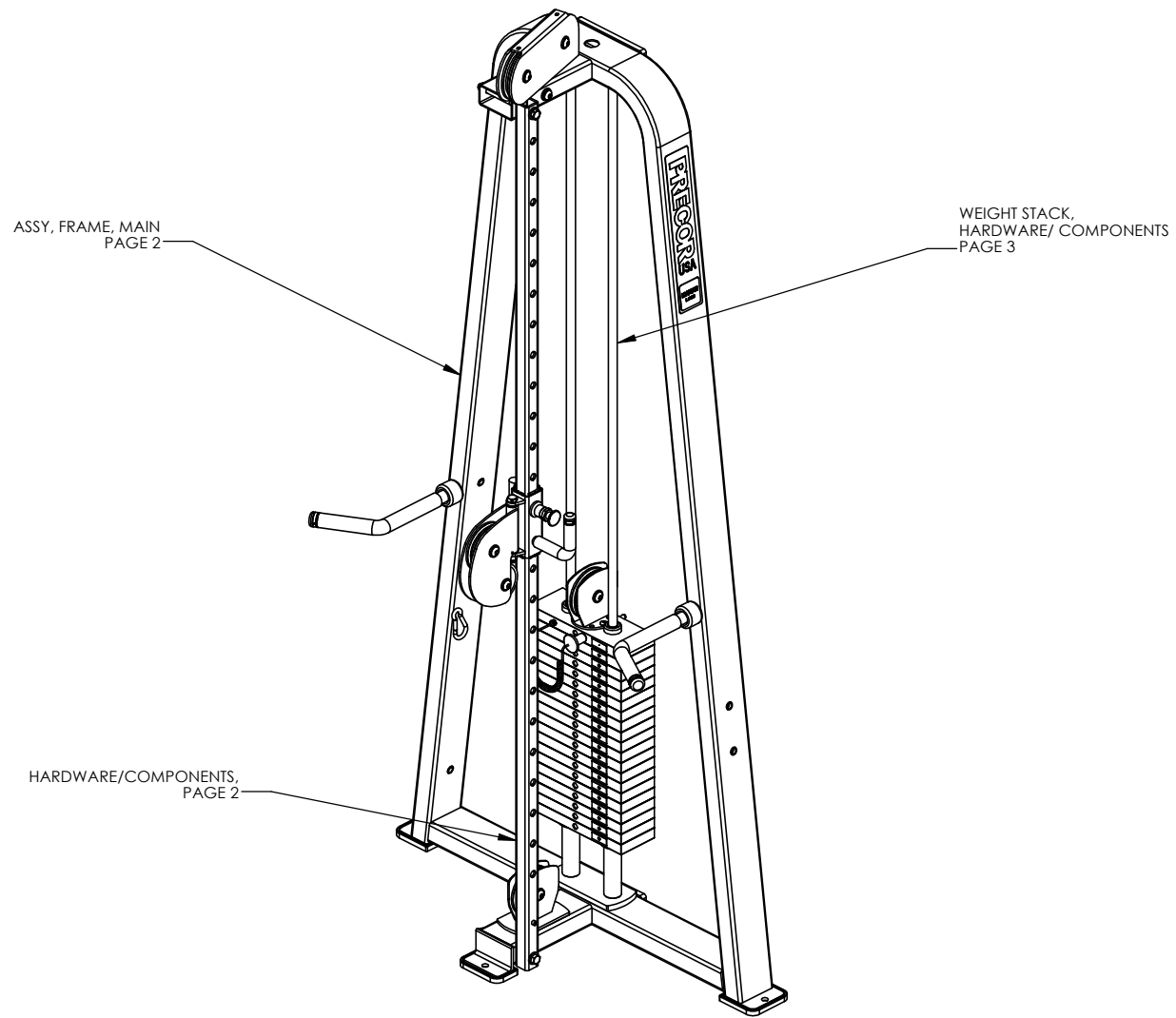

ASSY, FRAME, MAIN  
PAGE 2

WEIGHT STACK,  
HARDWARE/ COMPONENTS  
PAGE 3

HARDWARE/COMPONENTS,  
PAGE 2

P/N: CW34920-401		SUBREV: A
DRAWN BY: VLE	DATE: 06.24.09	SHEET 1 OF 3



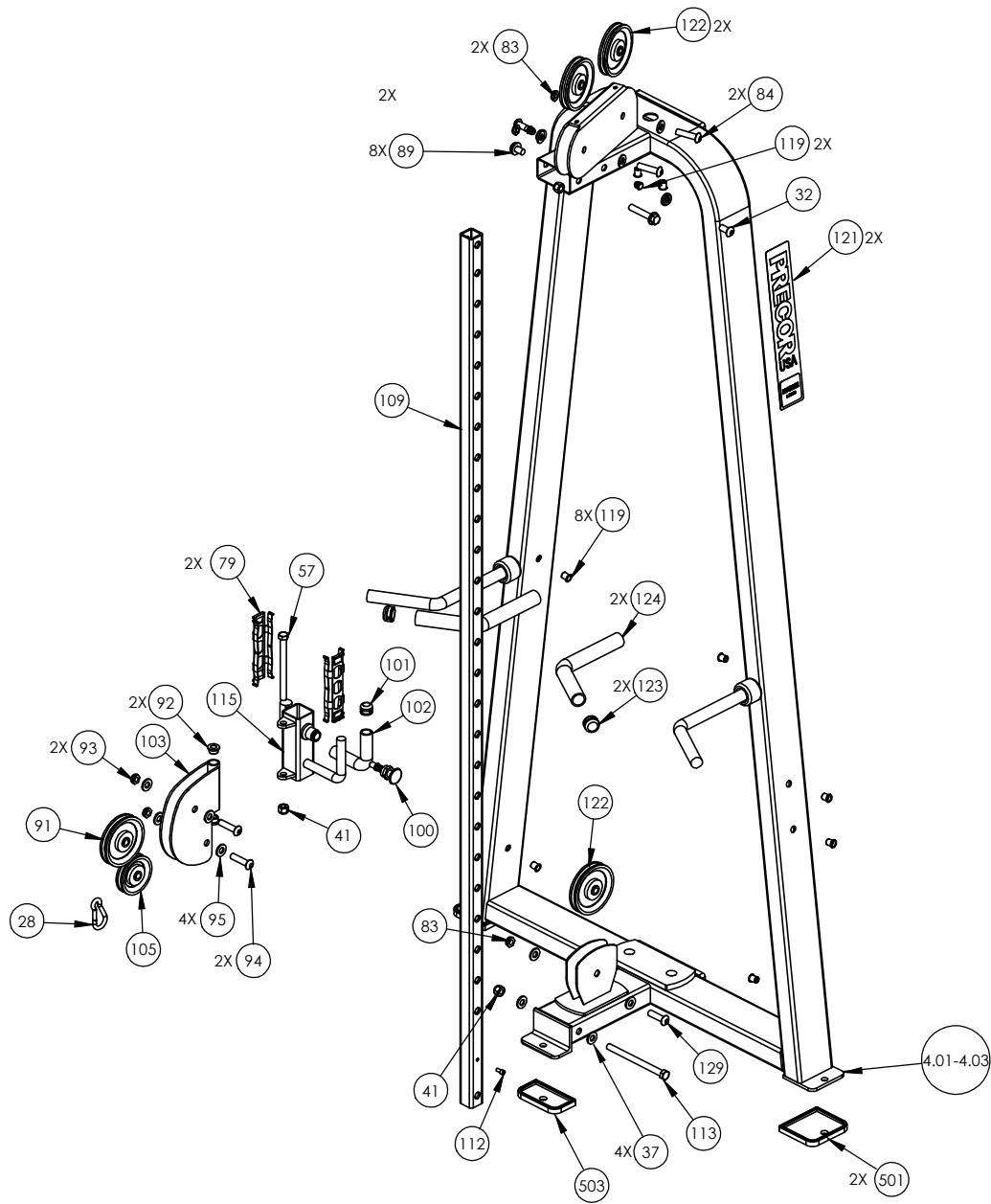

P/N: CW34920-401	SUBREV: A
DRAWN BY: VLE	DATE: 06.24.09
SHEET 2 OF 3	

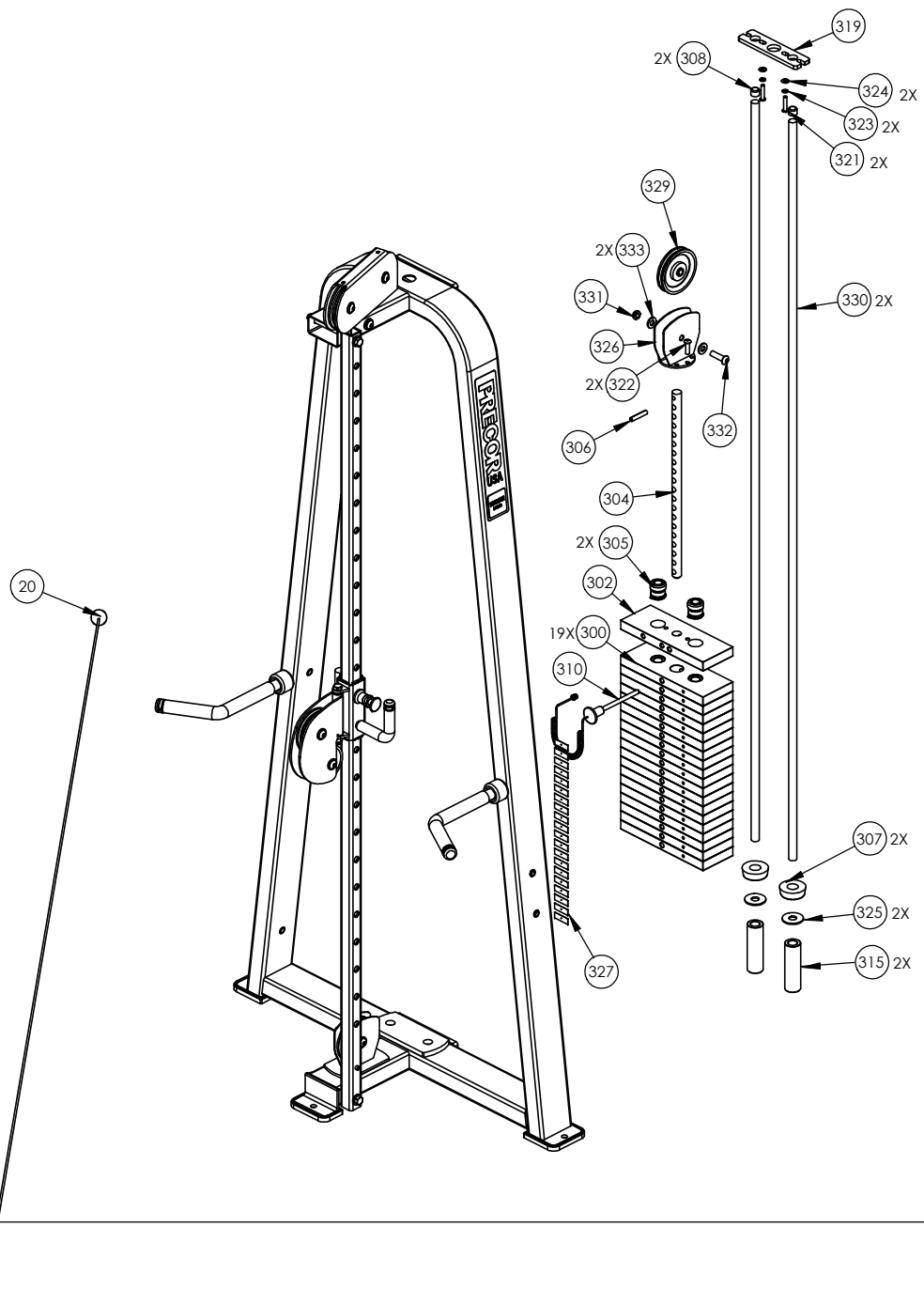

P/N: CW34920-401	SUBREV: A
DRAWN BY: VLE	DATE: 06.24.09
SHEET 3 OF 3	

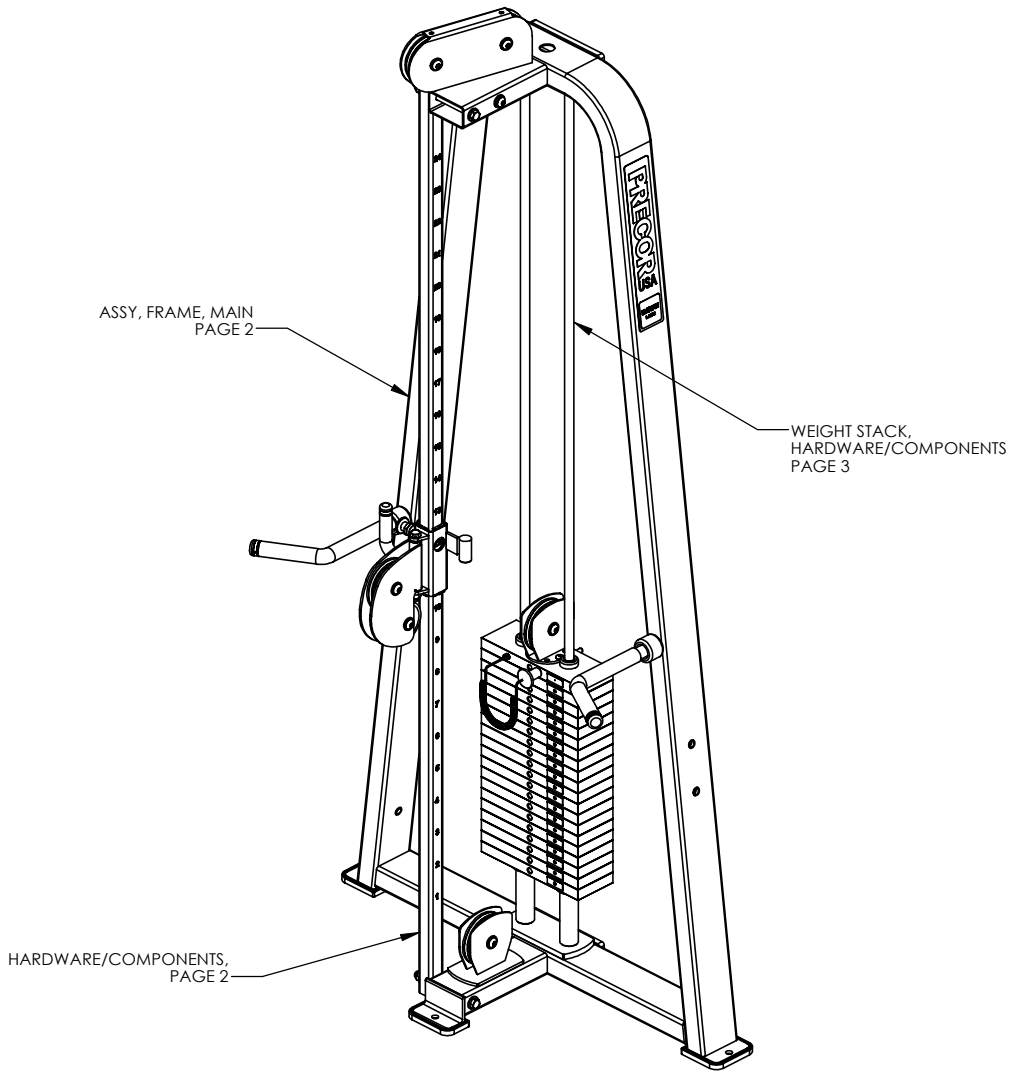

P/N: CW34921-401	SUBREV: A
DRAWN BY: VLE	DATE: 06.24.09
SHEET 1 OF 3	

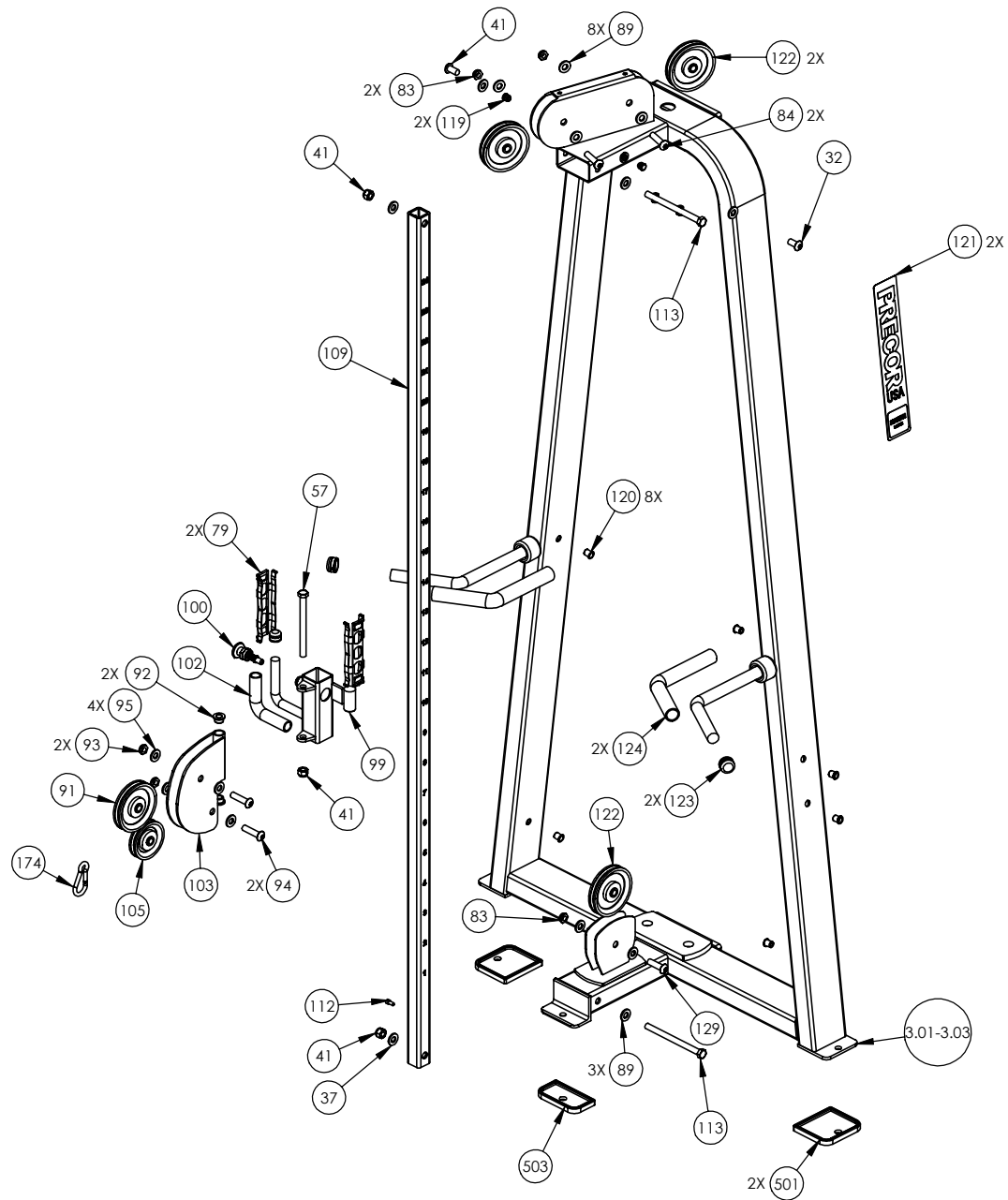

P/N: CW34921-401		SUBREV: A
DRAWN BY: VLE	DATE: 06.24.09	SHEET 2 OF 3

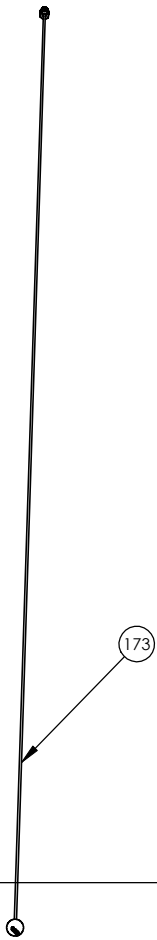
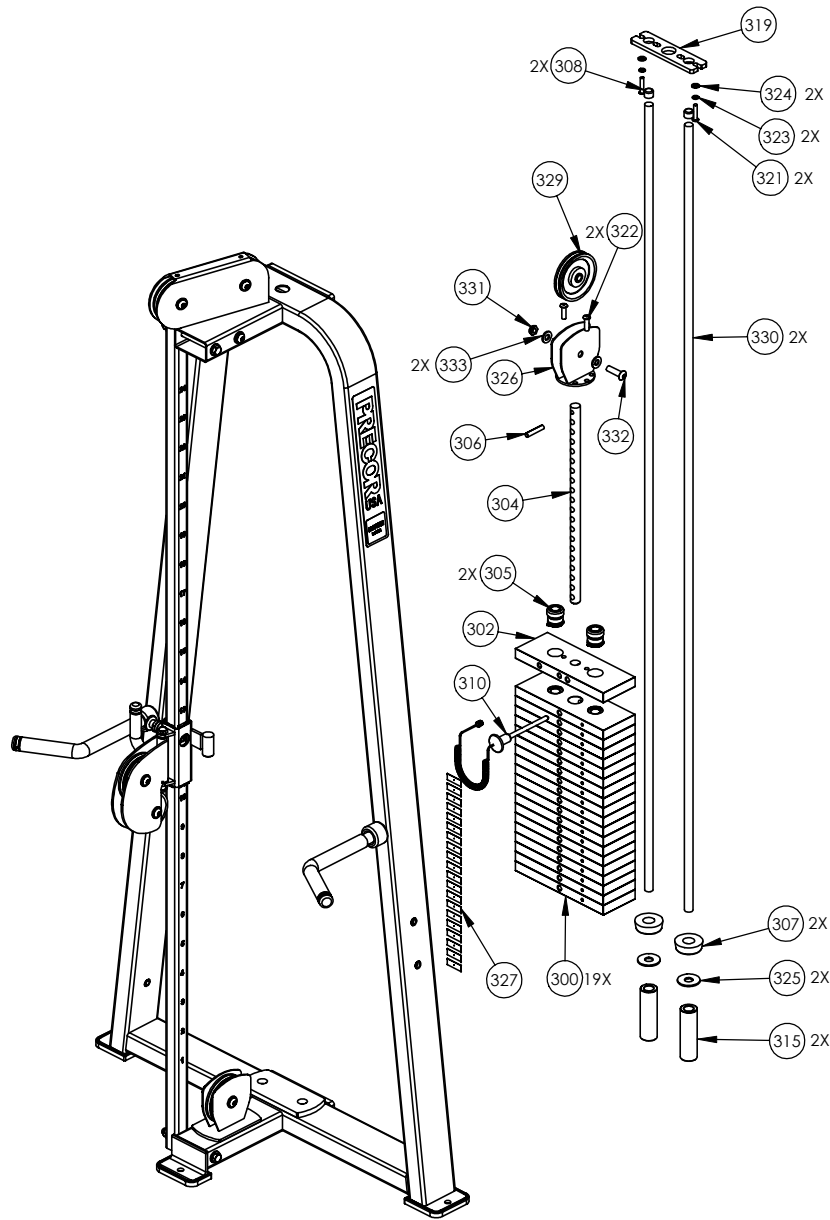

P/N: CW34921-401	SUBREV: A
DRAWN BY: VLE	DATE: 06.24.09
SHEET 3 OF 3	

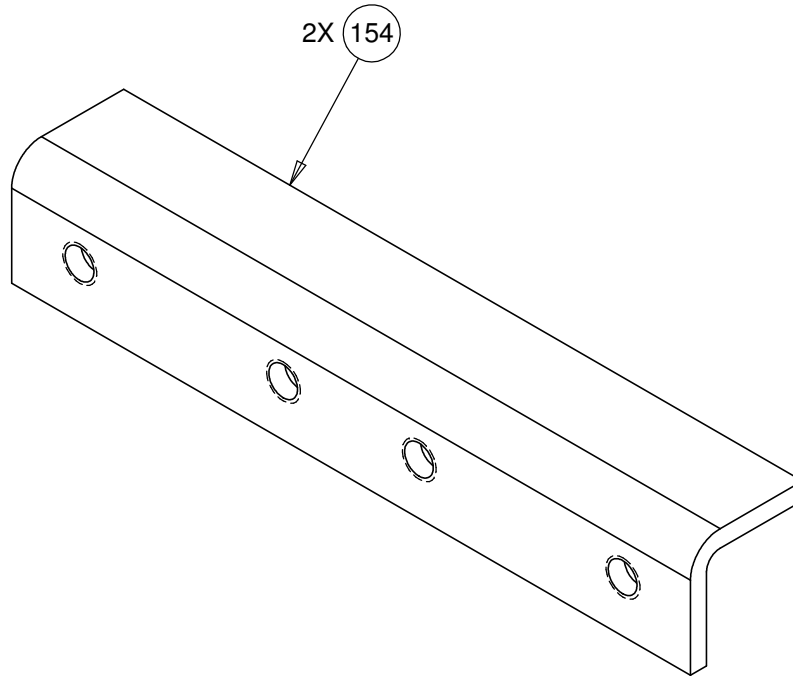

**CONFIDENTIAL**

THIS DOCUMENT AND INFORMATION CONTAINED HEREIN IS PROPRIETARY AND CONFIDENTIAL TO PRECOR STRENGTH INCORPORATED. RECIPIENTS OF THIS DOCUMENT AGREE THAT THIS DOCUMENT AND INFORMATION WILL NOT BE USED FOR ANY PURPOSE, REPRODUCED OR COPIED, OR DISCLOSED TO ANY THIRD PARTY, EITHER IN WHOLE OR IN PART WITHOUT PRIOR EXPRESS WRITTEN PERMISSION OF PRECOR STRENGTH INCORPORATED.

**PRECOR USA**  
PRECOR STRENGTH, INC.

**28936 AVE WILLIAMS  
VALENCIA, CA 91355  
TELEPHONE: 661-362-0300**

SIGN IN BLUE OR BLACK INK ONLY			UNLESS OTHERWISE SPECIFIED: DIMENSIONS ARE IN INCHES TOLERANCES ARE:		
DRWN BY	08.27.09	VLE	LIN	.X=±0.1	.XXX=±0.010
DWG CHK			LIN	.XX=±0.02	.XXXX=±0.0001
ENG	08.27.09	VLE	ANGULAR: ±1.0°		
MFG ENG			ALL DIMS AFTER PLATING		
CS			BREAK ALL SHARP EDGES		
QA			REMOVE ALL BURRS		
ID			ALL ANGLES & BENDS 90°		
REG			DWG PER ASME Y14.5M-1994		
			DO NOT SCALE DRAWING		
			125° ALL MACHINED SURFACES		
			SIZE	PAGE	OF
			A	1	1

PRODUCT:  
**STRENGTH**

**STEEL, CHANNEL**

DWG. NO. **CW33293-402** SUBREV **A**

HANDLES/COMPONENTS  
SHEET 3

CARRIAGE/SLIDES,  
SHEET 3

WEIGHTS/GUIDE RODS,  
SHEET 4

FRAME/C-FRAME,  
SHEET 2

CW320KS	P/N: CW33596-101	SUBREV: C
DRAWN BY: JEC	DATE: 09.11.08	SHEET 1 OF 4

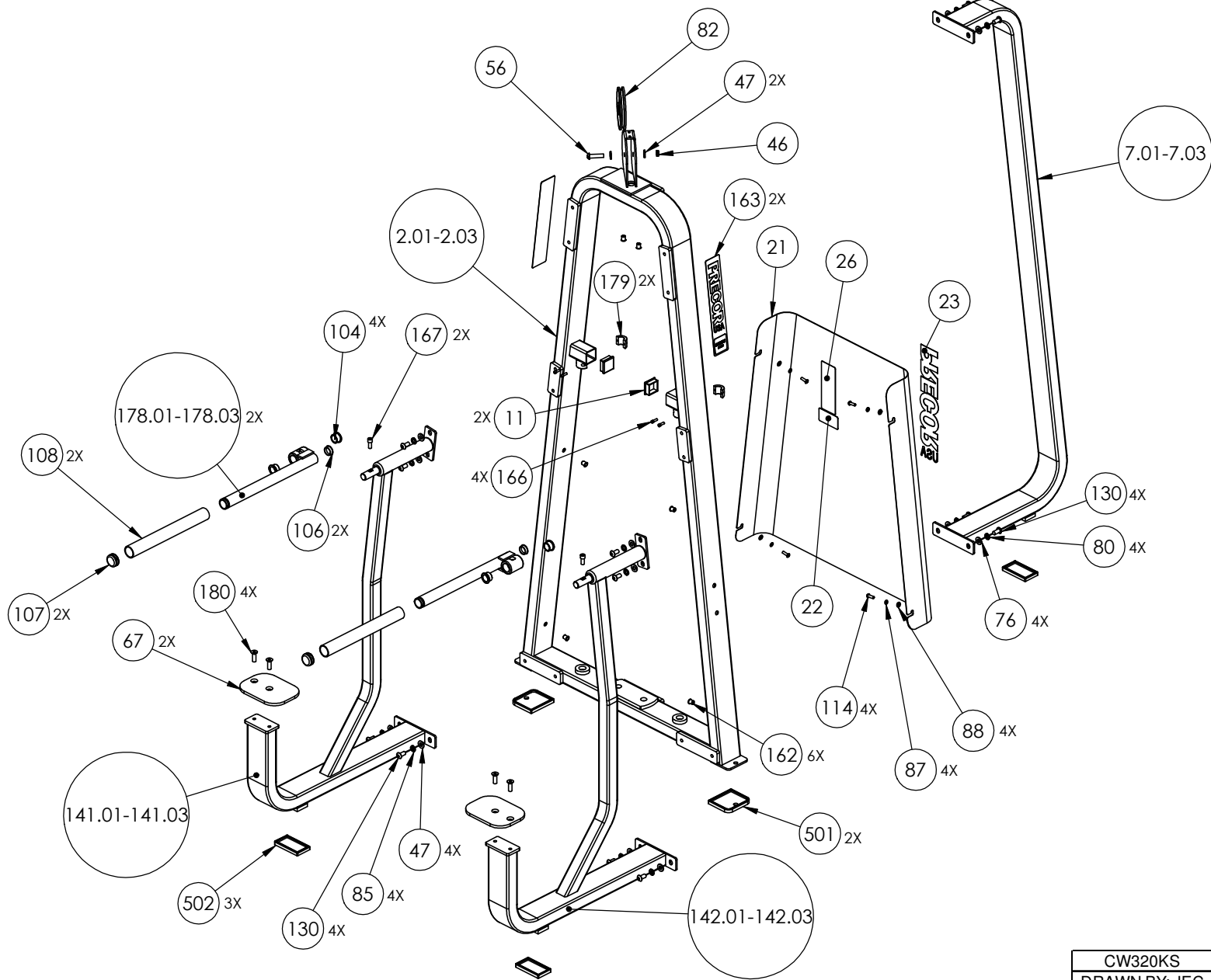

CW320KS	P/N: CW33596-101	SUBREV: C
DRAWN BY: JEC	DATE: 09.11.08	SHEET 2 OF 4



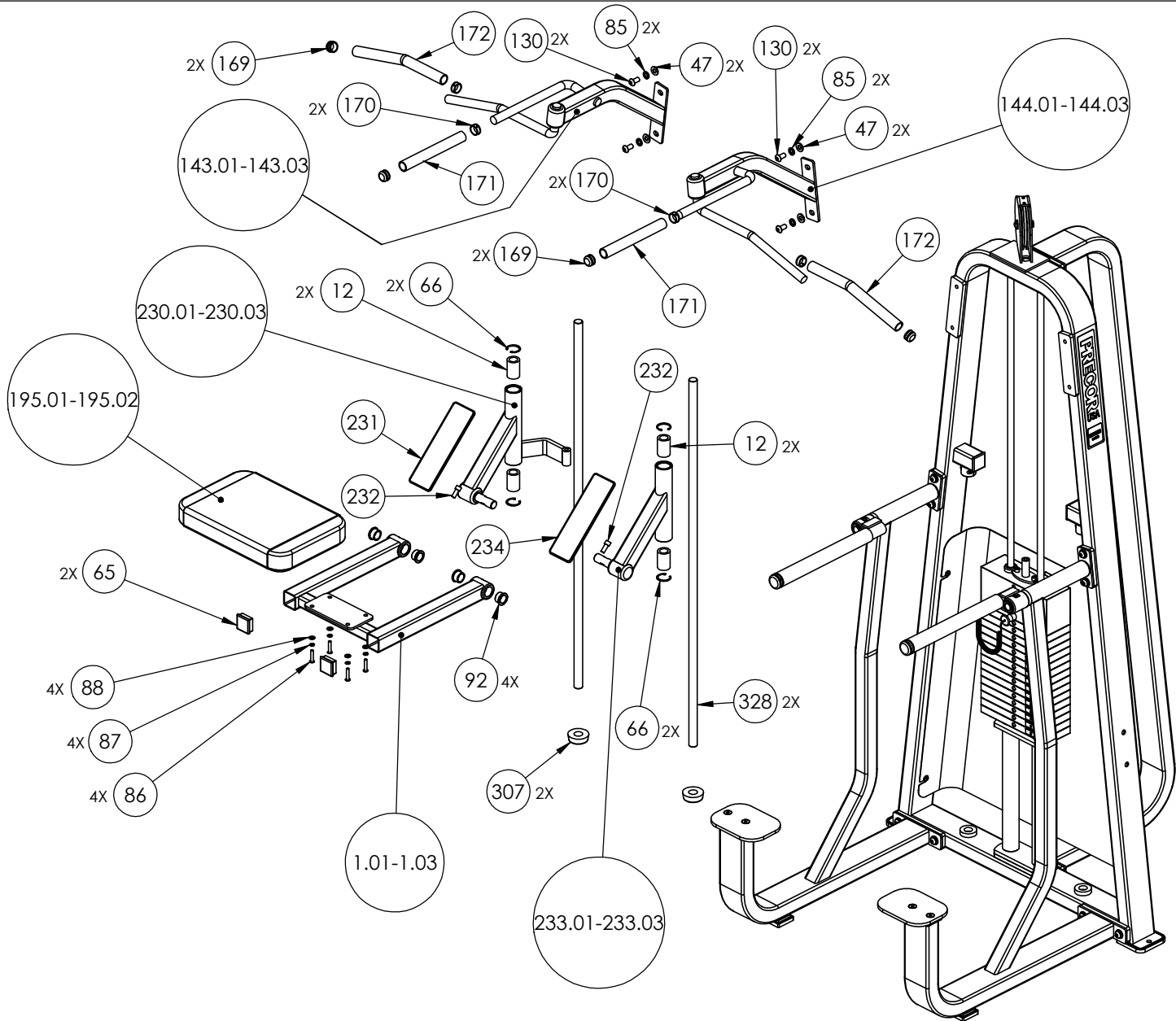

CW320KS	P/N: CW33596-101	SUBREV: C
DRAWN BY: JEC	DATE: 09.11.08	SHEET 3 OF 4

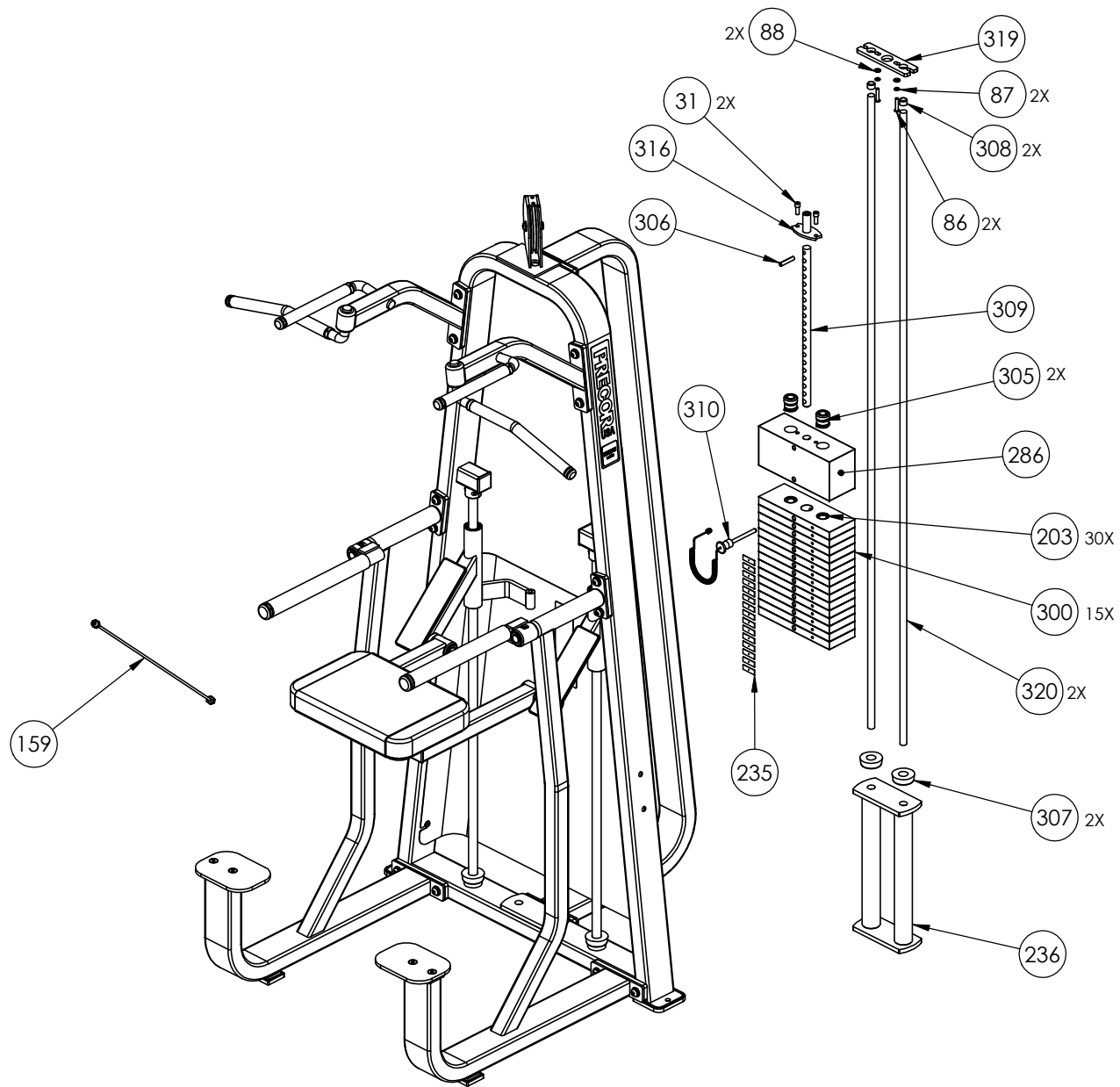

CW320KS	P/N: CW33596-101	SUBREV: C
DRAWN BY: JEC	DATE: 09.11.08	SHEET 4 OF 4